

# Driver's Anti-drowsiness System

Amarsinh Vidhate, professor  
Department of Computer Engineering  
Ramrao Adik Institute of Technology  
Navi Mumbai, India [amar.vidhate@rait.ac.in](mailto:amar.vidhate@rait.ac.in)

**Abstract**—In recent years, there is a significant and notable growth in online vehicle transport system, especially commercial vehicles where drowsiness and fatigue driving is a major transport safety concern. It is a main reason for thousands of accidents & fatalities every year. The resulting harms of drowsy/fatigue driving is more prevalent among commercial vehicles. An immediate attention is required as there are no formal checks for the vehicle drivers before they start driving the vehicle, especially commercial vehicles. Our system is a simple solution to all the drivers who want to give right confidence to them as well as passengers who travels using commercial vehicles.

## I. INTRODUCTION

Drowsiness is one the biochemical activity and most of the times it, depends on mental fatigue. Especially when the drowsiness is with respect to drivers mental fatigue, will create a killing trap for the passengers and even the driver also. The latest survey shows out of 5 accidents, 1 accident on the road, which is around 20% and increasing gradually every year. The major reason for accidents are due to driver's mental fatigue (drowsiness). The situation would become a nightmare due to road conditions, poor weather conditions, haste to reach the destination and excess of traffic also. There must be an assistant system to the drivers' activity, which monitors and assist the driver. To provide security to driver, the vehicles are assisted with automated safety system that alerts driver by using a alarm.

All vehicles should be equipped with driver drowsiness application and IOT device which is having pulse rate sensor and vibrator. The objective of this project is by using a driver drowsiness app the eye blink is measured. The mobile camera is used to observe the eyes of driver. If the eye is in close status, the alarm is triggered with toast in application. The IOT device is having pulse rate sensor and vibrator.

The rest of the paper is organized as follows. Section II is about the Motivation. Section III discusses about the problem definition. In section IV, we discuss about the related work and H/w & S/w requirement along with the proposed methodology. In Section V, a discussion about the design of a system along with the results in section VI.

## II. MOTIVATION

Whenever someone is driving a car from one place to another, they need to make ensure that they are not sleepy or feeling drowsy otherwise it can cause some serious problem such as accident. For this purpose, a surveillance system such as android app which uses mobile camera for detecting driver drowsiness is required which can monitor driver every other second. Due to this system, if by chance driver sleeps while driving the car, alarm will buzz off in high volume until it wakes up the driver. These types of systems can reduce no of road accident occurring each year[1][2][3].

## III. PROBLEM DEFINITION

In recent years, there is a significant and notable growth in online vehicle transport system, where users can use public transport (commercial Vehicles) many times, by using online booking softwares. However, there are many incidences where the drivers lost their control and the accidents happen. The major reason is the driver's long working hours, their payments system based on running mileage etc. This traditional system brings the drivers into heavy mental fatigue state and that lead to accidents.

Drowsiness is a biological activity based on your mental fatigue. This is a serious issue that leads to thousands of severe accidents every year and the number is increasing day by day. It may lead to vehicle collisions, high number of deaths, disability, substantial financial loss/ cost to the driver and the dependents. There is a tremendous necessity of Some kind of systems like driver fatigue monitor, real time vision based on driver state monitoring system, seeing driver assisting system, user centric drowsiness driver detection and working system are to be

implemented immediately. The proposed system is a driver's assistance system which takes the driver into a specific line of action (test) so that the driver must pass every test and always remain alert in any of the driving period.

#### IV. PROPOSED SYSTEM

##### A. Literature Study

- M.J. Flores et al. [4] has proposed a driver drowsiness detection system which works under infrared illumination for an intelligent vehicle. It is been targeted to reduce the amount of fatalities with the help of advanced driver assistance module which detects the drivers distraction and drowsiness using AI based algorithm. The algorithm is used to process the visual information in order to locate, track and analyze the driver's face and eyes to compute the drowsiness and distraction indexes. The best advantage of the system which works during nocturnal conditions due to a near-infrared lighting system. The author has validated the results by using different drivers images captured real time in nocturnal conditions.
- "Driver Drowsiness Recognition Based on Computer Vision Technology" has been proposed by W. Zhanget al.[5]. It is basically a nonintrusive drowsiness recognition method which uses an eye-tracking and image processing. The author has proposed an eye detection algorithm to address the problems caused by changes in illumination and driver posture. Overall total six measures are calculated with percentage of eyelid closure, maximum closure duration, and blink frequency, average opening level of the eyes, opening velocity of the eyes, and closing velocity of the eyes. These measures are combined using Fisher's linear discriminated functions using a stepwise method to reduce the correlations to extract an independent index. The results with six parameters in driving simulator experiments demonstrate the feasibility of the video-based drowsiness recognition method that provided.
- Garcia et al. [6] has proposed a Low-Cost 3-D Sensor based Driver Monitoring system which not only monitor driver activity but also event detection based on 3-D information based on the range of the camera. The important measures like head pose estimation along with regions-of-interest identification have been considered. Author has discussed a login which is based on the captured cloud of 3-D points from the sensor and analyzing the 2-D projection, the points corresponding to the head are determined and extracted for further analysis. Further, head pose estimation with 3 degrees of freedom (Euler angles) has been estimated based on the iterative closest point's algorithm. Lastly, relevant regions of the face are identified and used for further analysis, e.g., event detection and behavioral analysis which ultimately results into a 3-D driver monitoring system based application on low-cost sensors. It represents an interesting tool for human factor research studies, allowing automatic study of specific factors and the detection of special event related to the driver like driver drowsiness, in attention, or headposing.
- Youchi Saip et al. [7] has Proposed an assistance system that implements a partial control if the lane depart and gives a driver a chance to take volunteer action. In case the expected action won't be taken by the driver, the system will take that. The author has proposed a system which takes care if the driver is asleep, immediately switch to the suggested system.
  - A. Subbarao et al. [8] has proposed a system which will accurately scrutinize the eye blink. There is an IR based eye blink sensor which detects the driver's eye. The inconsistency across the eye with various samples will vary as per eye blink. A simple logic like when the eye is closed, the output is high or else low. The output from IR is given to alarm circuit to buzzer in case of an alert. The controller will send a warning signal so that the buzzer, which is placed near the driver, will be activated and alerts the driver when he falls asleep during driving. The alcohol sensor is also used to detect whether the driver is drunken which avoids accident caused by the drunken drivers. The importance of alcohol sensor should be directly related to whether to allow driver to start vehicle or not.

##### B. Details of Hardware/Software Requirement

###### Hardware Requirements [6]

- Arduino Uno Kit
- Bluetooth Module(HC-05)
- Pulse Rate Sensor
- Vibration Motor
- Vibration Motor
- USB Cable And Wires

SoftwareRequirements

- AndroidStudio

C. ProposedMethodology

Before driving the car the driver need to meet certain conditions which are alcohol test along with pulse rate test. In alcohol test if the driver has a specified alcohol value greater than 0.03 g/dL then we will directly stop him/her from driving the car. If alcohol condition is less than 0.03 g/dL then we go on calculating pulse rate for 5 sec continuously which is calculated by storing the average heart rate value in avg variable and if the drivers' heart rate is normal then it will start driving the car. Once the driving has been started we will continuously monitor drivers face by using mobile camera provided in application along with that we will also calculatedrowsinessheartratebysubtractingtheavgvalueby 8 to obtain the new data store in db. From face detection we will calculate drivers' eyes probability whichshouldbeless than 0.5 and if this condition is not satisfied then we will go on comparing current heart rate value with db. If the condition for eye's probability or current heart rate is equal to db value then alarm is buzz of with alert message "drowsiness detected" along with increasing volume as well as vibratorwill alsoprovidemildshockfor5secondsuntildriverwakesup.

All these data is being continuously fetched via Bluetooth to the central device which is driver drowsiness application.

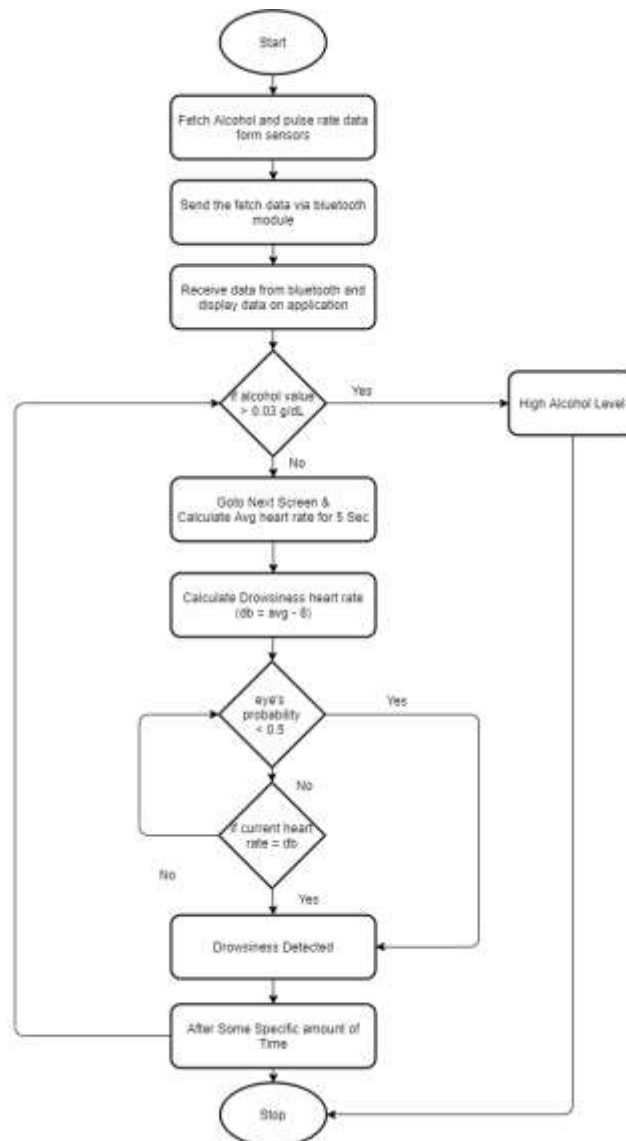

Figure 1: Algorithm flowchart

## V. DESIGN OF SYSTEM

### A. Design Diagram with Explanation

The system structure shows in fig 1. The pulse rate sensor measures the heartbeat and send it to the microprocessor. Then this data is sent by Bluetooth to driver drowsiness application. Driver drowsiness app is used for eye detection of driver. In the following, we explain the main components of relevant devices.

- Bluetooth transmission module (HC-05) - It is used to send the heartbeat data (measure by the pulse rate sensor) to driver drowsiness application [9].
- Microprocessor (Arduino Module)-It is connected to the Bluetooth transmission module which contains an extraction unit, a memory unit and a compiling unit. The memory unit temporarily stores the image data for subsequent usages. The extraction unit extracts data from pulse rate sensor [10] [11][12].

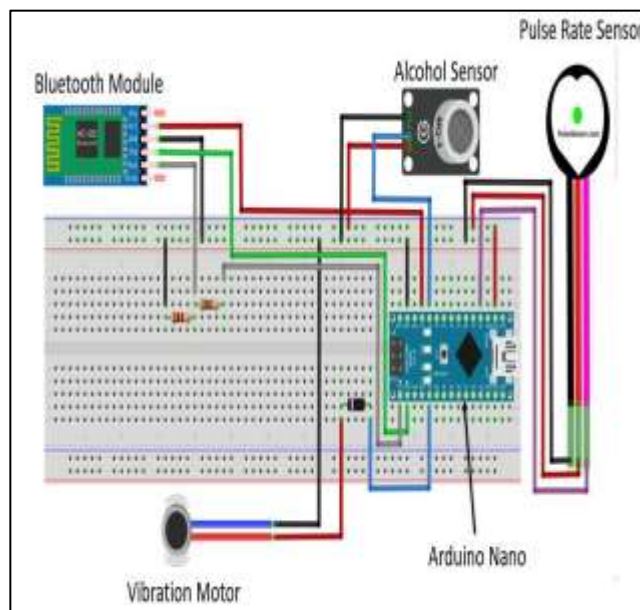

Figure 2:IoT System Prototype

- Pulse rate sensor- It is installed on the microprocessor to measure heart pulse wave. This sensor has a pair of infrared emitter and detector diode that placed side by side to detect clear ECG signal[9][10].
- Alcohol Sensor (MQ-3) - This sensor provides an analog resistive output based on alcohol concentration. When the alcohol gas exist, the sensor's conductivity gets higher along with the gas concentration rising[9][10][11].
- Vibrator- Vibrator is a device that vibrates when it plugged in low voltage 5V. It is used as the output of the system. When the driver starts to feel drowsy, the micro-controller will turn the vibrator ON as to alert the drive [9].
- Android device- Android device running with minimum android version 5.0(Lollipop) which is having driver drowsiness application for drowsiness detection of the driver[10][12][13].

This is the next stage where the driver's drowsiness is detected by monitoring his/her face [13][14][15][16][17]. There is a status bar which gives user status as active/sleepy/drowsy/Face Missing. Active status indicates that the face is completely being analyzed. Sleepy status occurs when driver is being detected for sleeping more than 5 times while driving. Drowsy status occurs when driver is being detected for sleeping more than 8 times. Face Missing status occurs when we put some object in front of camera so that it is unable to detect any face. An end button is also present when pressed will end that complete

session and it will give the final status from anyone explained above. There is also an N Mode which indicates night mode for that mode to activate you need to press that button and once it has activated the user needs to increase mobile phone maximum brightness to capture the face.

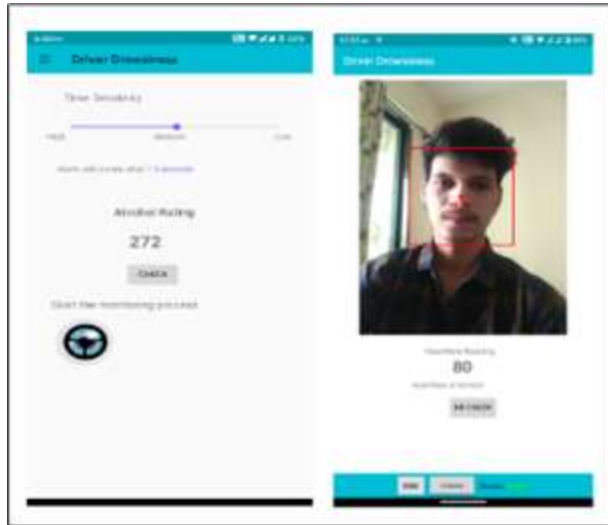

Figure 3: Timer Set & Face Detection

## VI. RESULTS

### A. Implementation Details

This is the first page of the app where we set the timer between high, medium or low as per the user's then we start taking alcohol reading if the user passes the alcohol test then user can press the start button below to start the face monitoring process.

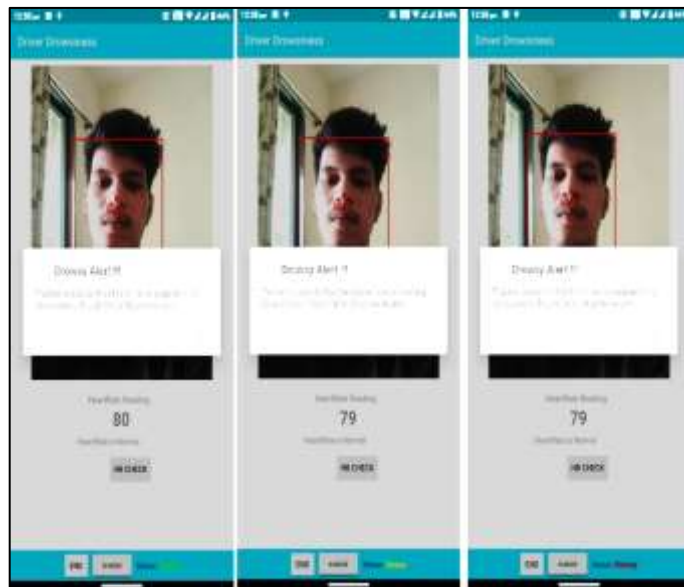

Figure 4: Drowsiness Alert



Figure 5: Ready Device with wearable gloves

When the driver sleeps for more than he specified timer an alarm will start ring on high volume until the driver wakes up. This is the message which is displayed when driver is sleeping. There are two images with status as Drowsy and Sleepy when driver has been sleeping continuously for several time.

In fig 5, a complete ready device with wearable Glove is shown. The driver need to wear it before he/she want to start driving vehicle. The driver need to pass on all the tests without fail to proceed

**B. Project Outcomes**

There are few tests done for its accuracy by providing these gloves to the local drivers for getting their feedback. The parameters which are taken to observe the feedback provided by driver are given below:

1) Detection levels under special conditions

Few observations noted including different conditions than normal such as the driver wearing spectacles or the driver wearing a cap, etc.

TABLE I  
DETECTION LEVELS UNDER SPECIAL SPECIFICATIONS

Test	No of Observations	No of Hits	Percentage of Hits
Driver Wearing Cap	30	25	84%
Driver Wearing Glass	30	22	78%

2) Detection levels for other parameters. This section focuses on the observations of data while considering other factors like hair covering drivers Face/ not covering face.

TABLE II  
DETECTION LEVEL UNDER OTHER SPECIFICATIONS

Test	No of Observations	No of Hits	Percentage of Hits
Hair Covering Driver's Face	30	15	53%
Hair Not Covering Driver's Face	40	35	89%

The above tables discuss about the number of observations and taken multiple times. Both the table discuss about the percentage of hits and how the device will alert about the drowsiness thru various alert conditions.



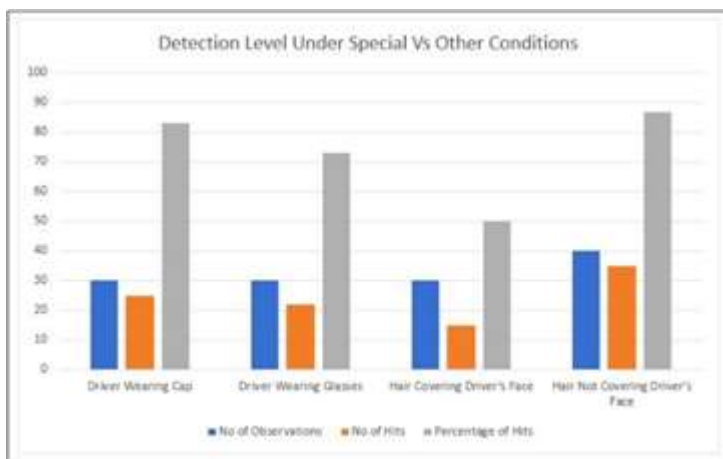

Figure 6: Detection Levels under various conditions

## VII. CONCLUSION AND FUTURE RESEARCH

The said system proposes a drowsiness detection system based on driver behavior. There are numerous test, the driver has to pass like alcohol sensing, heart rate sensing, eye's movement etc. The role of the system is to detect facial landmark from images that are collected while the person is driving the vehicle by a mobile camera attached to the vehicle and process the obtained data to identify driver's state. Once the collected data is detected to be showing signs of drowsiness the person will be alerted using the speakers of mobile in high volume until the person wakes up or stop the vehicle to avoid any accidents due to his drowsy state. According to the experimental results, the size of the application is small while having the accuracy rate of 86 % from driver. The future work will be focused on detecting yawning and pulse of the driver while driving the vehicle.

Our future research system will extend these alert messages to nearby vehicles using V2V network so that if the driver is not coming out of drowsiness, it would be a danger for other vehicles. Our future proposal includes alert message to the nearby vehicles followed by the Road Transport police also.

## VIII. REFERENCES

- [1] A Rathod, A Yadav, B Sangle, R Rathore, "Driver drowsiness monitoring system using visual behavior and machine learning," iscaie 2018 -2018 IEEE symposium on computer applications and industrial electronics, 2018.
- [2] D S Shilvant, S Nagargoje, "Drowsiness detection system for car assisted driver using image processing," international journal of electrical and electronics research, 2017.
- [3] M. Hemamalini, P. Muhilan, "Accident prevention using eye blink sensor", vol 1, Issue L11, 2017.
- [4] M. J. Flores, J. M. Armingol, A. Escalera, "Driver drowsiness detection system under infrared illumination for an intelligent vehicle," IET Intelligent Transport Systems, 2011, Vol.5, PP.241-251.
- [5] W. Zhang, Bo Cheng, Yingzi Lin, "Driver drowsiness recognition based on computer vision technology," Tsinghua Science & Technology, 2012, Vol.17, pp354-362.
- [6] I Garcia, S Bronte, T Soukupova, J Cech, " Vision-based drowsiness detector for real driving conditions," IEEE intelligent vehicles symposium. 2012.
- [7] Yuichi Saito and Makoto Itoh and Toshiyuki Inagaki, "Driver Assistance System With a Dual Control Scheme: Effectiveness of Identifying Driver Drowsiness and Preventing Lane Departure Accidents," IEEE Transactions on Human-Machine Systems, 2016, vol-46, pp-660-671
- [8] Subbarao, K.Sahithya, "Driver Drowsiness Detection System for Vehicle Safety," International Journal of Innovative Technology and Exploring Engineering (IJITEE), ISSN: 2278-3075, Volume-8, Issue- 6S4, April 2019
- [9] J. Deogirikar and A. Vidhate, "Security attacks in IoT: A survey," 2017 International Conference on I-SMAC (IoT in Social, Mobile, Analytics and Cloud) (I-SMAC), 2017, pp. 32-37, doi: 10.1109/I-SMAC.2017.8058363.
- [10] Tejaswini Jagdale, Pradnya Jadhav, Prajakta Totre, Mayura Zadane, Shrilekha Mankhai, "Driver drowsiness detection, alcohol detection and accident prevention", IJET, vol3 issue1, Jan 2017.
- [11] R. Simons, M. Martens, J. Ramaekers, A. Krul, Klöpping-Ketelaars, and G. Skopp, "Effects of dexamphetamine with and without alcohol on simulated driving," Psychopharmacology, vol. 222, no. 3, pp. 391-399, 2012.
- [12] Eddie E. Galarza, Fabricio D. Egas, Franklin M. Silva, Paola M. Velasco, Eddie D. Galarza, "Real Time Driver

- Drowsiness Detection Based on Driver's Face Image Behavior Using a System of Human Computer Interaction Implemented in a Smartphone," Proceedings of the International Conference on Information Technology & Systems (ICITS 2018), 2018, Volume 721, pp-563-572.
- [13] L. Deshpande, K. Soni, S. Junawane, P. Jagtap, "Real-time driver drowsiness detection for android application using deep neural networks techniques," Proceedings of the International Conference on Computer Science, 2015.
- [14] T. P. Nguyen, M. T. Chew and S. Demidenko, "Eye tracking system to detect driver drowsiness," 2015 6th International Conference on Automation, Robotics and Applications (ICARA), Queenstown, 2015, pp. 472-477.
- [15] Ramalatha Marimuthu, A. Suresh, M. Alamelu and S. Kanagaraj, "Driver fatigue detection using image processing and accident prevention", International journal of pure and applied mathematics, vol. 116, 2017.
- [16] Bappaditya Mandal, Liyuan Li, Gang Sam Wang and Jie Lin, "Towards detection of bus driver fatigue based on robust visual analysis of eye state", IEEE transaction on intelligent transportation systems, 2016.
- [17] Suhaskatkar, Mahesh Manik Kumbhar, Priti Navanath Kadam, "Accident prevention system using eye blink sensor", IRJET, Vol.03 Issue 05, 2016.